

# CHAPTER 1

## Introduction

### 1.1 Background and Motivation

A recent survey attributes that 92% of all disturbances in power system is caused by voltage sags [1] from that caused voltage sags can be classified in seven types [2] as shown in Figure 1.1. The voltage sags may typically be triggered by natural causes (by lightning or an accident from disaster) or by some loading conditions (start-up of large motor drives or rectifiers without soft starters/pre-charge circuits which draw large inrush currents, and arc furnaces exhibiting low impedance and unbalanced load characteristics and drawing large magnitude unbalanced currents).

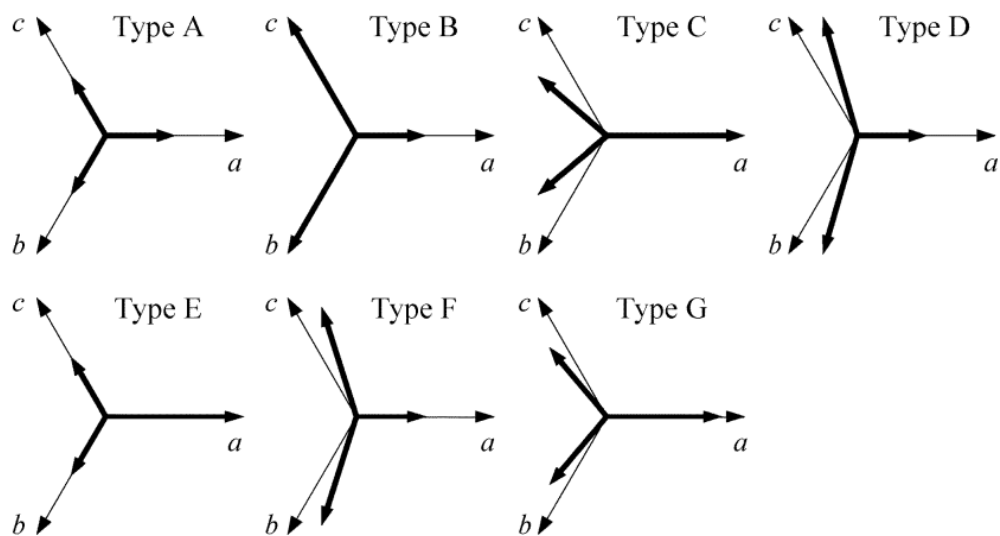

Figure 1.1 The seven types of voltage sag. [2] all sags have a magnitude of 50%

They are the most frequent power quality problems in the power grid, and they usually have high economical impact on the voltage-sensitive loads. The sensitivity of the equipment fed from the ac grid to voltage sags can be decreased to sufficient levels by design or by utilization of auxiliary devices. For example, in electronic boards fed from

switch-mode regulators and in inverter drives using ac/dc rectifier stage, the rectifier stage can be designed to sustain operation during voltage sags. In such systems, the rectifier stage involves an electrolytic capacitor bank for rectifier output voltage filtering. By increasing the size of the electrolytic capacitor, the energy storage capability of the device can be increased to a sufficient level to maintain power to the load during a voltage sag, and processes may be halted. Repair and restart of the processes usually are involved and costly

From the voltage sags effect, this research need to know the behavior of the sag sensitivity of equipment and certainly standard. For example, information technology equipment must meet the Information Technology Industry Council requirements, which define sag duration and depth as combined criteria and establish an operability envelope for ride-through operation [3]. In industrial processes, the electronic boards of the systems/instruments (programmable logic controllers (PLCs), instrument power supplies, etc.) are also highly sensitive to sags such that a standard for this purpose was established (IEC-61000-4-11 [4]). Similarly, power line conditioners must meet certain sag ride-through conditions. Such as, in UPS systems and voltage regulators (static or variable transformer dc servo based), load regulation for a varying line voltage range is defined. Typically, UPS systems provide nominal output voltage for an input voltage variation of  $\pm 25\%$ , while voltage regulators usually are designed to operate in a wider range.

In all such cases, during the design, development, and certification of such devices, voltage sag tests (according to standards such as IEC-61000-4-11 [4] and SEMI F47 [5], or the specification of manufacturer and customer) must be conducted to confirm the sag ride-through capability of the system. Therefore, in university and industry research laboratories, standards and certification institutions, etc., sag generators are required. As defined in the IEC-61000-4-11 standards, typical sags last for 0.5–30 times (class 2) the power line period, and their depth can be 10%–90%. Thus, sag generators must provide

voltage sag in this range. In all the sag-generating equipment, the main desirable feature is the easy and free programmability of the sag duration and depth.

In addition to the sag duration and depth, there are two more parameters in defining the sag, which are the point of initiation and phase shift [6], [7]. Although these two additional parameters are helpful in completely defining a sag condition, their impact on the equipment under test has been found quite limited [8],[9] and the difficulty in including them in the sag-generating equipment is very high (in terms of both cost and complexity). In summary, simple voltage sag generator circuits are essential test equipment for the purpose of sag studies (imitation, mitigation, etc.).

Commercially available and/or literature-reported sag generators are usually complex and expensive. They are usually offered by a few international specialized test and instrumentation equipment manufacturers as custom design products at very high cost. For ratings less than several kilovolt–amperes, sag generator can be simply classified into 4 types [10]. These four types of voltage sag generator are transformer, switching-impedance, generator and amplifier. Autotransformer and electronic-circuit-based (linear or switch mode) sag generators [11], [12] are used, and for higher power ratings, either autotransformer with tap-changing windings (using contactors or thyristor-based static switches) [13] or rotating machine (synchronous generator) [14], [15] based configurations are used. While the electronic units are limited in power rating and usually complex and very expensive, the latter types are bulky and complex. With all such systems requiring advanced design, such equipment is best purchased from a custom design manufacturer and usually at high cost and limited flexibility. In addition, repair and maintenance of such equipment require the expert knowledge, rendering the user of the equipment in the hands of the manufacturer and its servicing capability. Several university laboratory-built relatively simple sag generators have also been reported. The triac-structured solid-state-relay (SSR)-based sag generator in [16]-[19] has limited performance due to the discontinuity in the voltage waveform. The method using insulated-gate bipolar transistor (IGBT) switches [20] can provide instantaneous voltage sag, but involves snubbers and detailed gate drive circuitry, which requires

specialists' effort to design such a sag generator. The amplifier type in [21] can provide voltage sags with duration, frequency and harmonics. After defining the desired waveform data is passed to power amplifier, at which outputs of adequate voltage levels of voltage sag are produced. This type is more convenient than others types, because it enables more precise control of all voltage sag characteristics and also allows testing of equipment in context of frequency variations and harmonic distortions. But in [21] cannot adjust value of magnitude voltage sags output and using without program control. (in [21] called SagWave GUI program). And all of Topology of Voltage Sags Generator shown in Table 1.1

Table 1.1. The advantages and limitation of all topology of voltage sags generator

| Topology of Sag generator                  | Advantages   | Limitation  |
|--|--|---|
| Transformer tap, Auto transformer          | <ul style="list-style-type: none"> <li>- High power</li> <li>- Simple operation</li> <li>- low cost</li> </ul>   | <ul style="list-style-type: none"> <li>- Very heavy weight</li> <li>- Transformer design is complex</li> </ul>  |
| Generator based                            | <ul style="list-style-type: none"> <li>- High power applications</li> </ul>  | <ul style="list-style-type: none"> <li>- Very heavy weight</li> <li>- needs more space to install</li> <li>- High cost</li> <li>- Only emulates symmetrical voltage sags</li> </ul>   |
| switching-impedance, shunt impedance based | <ul style="list-style-type: none"> <li>- High power</li> <li>- Simple control Structure</li> <li>- Low cost</li> <li>- Fast switching</li> </ul>   | <ul style="list-style-type: none"> <li>- generated undesired harmonics</li> </ul>   |
| Amplifier                                  | <ul style="list-style-type: none"> <li>- compensate effectively reactive current, negative sequence current and zero sequence current due to unbalanced loads</li> <li>- Power electronics devices is low-cost</li> <li>- Allows phase angle control for three phase sags</li> <li>- Fast switching</li> </ul> | <ul style="list-style-type: none"> <li>- Low power applications</li> <li>- requires specialists' effort to design</li> <li>- needs quite a bit of digital logic and computational power</li> <li>- Complex control algorithm</li> </ul> |

In this research, a simple and economical, highly performing, sag generator will be developed, and its application for the test of a power quality conditioner will be demonstrated. The proposed three-phase four-leg generator using carrier-based three-dimensional space vector pulses width modulator (CBPWM) at 3-kVA rated shown in Figure 1.2. It has a very simple design, low-cost and can be easily develop and operate hardware structure. Therefore, it is suitable for most R&D and test labs to evaluate the performance of equipment under sag conditions (device under test or a sag-

compensating power quality conditioner), and balanced/unbalanced voltage sags, and phase shift voltage will be generated. The sag generator will be tested with resistive and inductive loads, and its performance entering and exiting a sag condition will be demonstrated. In addition, its performance will be demonstrated for a nonlinear (diode rectifier) load. Finally, the utilization of the sag generator in the test of a SAF-based power quality conditioner will demonstrate that the proposed method provides an effective method for voltage sag generation for the purpose of sag-compensating equipment testing and all tested based on IEC61000-4-11 and SEMI F47.

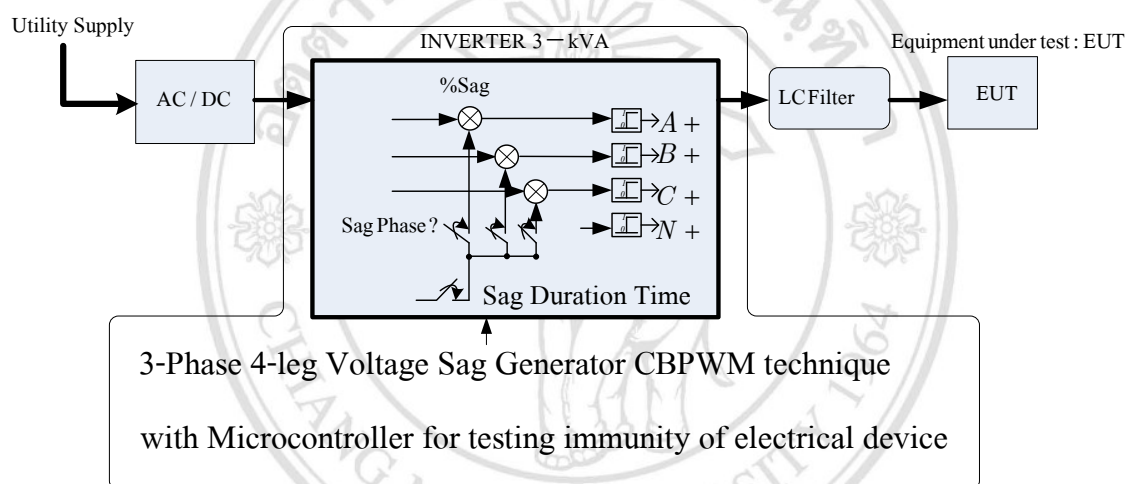

Figure 1.2 Voltage sag generator 3-phase 4-leg for testing electrical devices equipment.

## 1.2 Literature Review

Djokic *et al.*[6] presented characteristic of voltage sag, a critical and do detailed review of the relevant information about two often-neglected characteristics of voltage sags and short interruptions: point on wave of sag/interruption initiation and point on wave of sag/interruption ending. This paper review a critical, definition of point-on-wave values, an identification of point-on-wave values in monitoring applications, and problems related to identification/assessment of point-on-wave values.

Djokic *et al.*[7] presented characteristic of voltage sag, the phase shift. Firstly, a critical review of existing methodologies and approaches is presented. Then, theoretical and experimental results on the ranges and relationships of phase shift values are reviewed.

A numerical example and several recorded ‘non-conventional’ voltage sag waveforms are used to highlight some of the problems encountered in calculating a phase shift.

Collins and Morgan [14] presented a diesel powered three-phase standby 48W, 15kW, 60Hz synchronous generator has been modified to give controlled three-phase voltage sags. These sags can be controlled in both depth and duration. And disadvantages of this type are that it needs more space to install and is more expensive.

Teke *et al.*[15] presented the generator three or single phase voltage sags, swells, outages, harmonics, transients, phase shifts and flickers. The generator used auto transformer and thyristors. The transformer used with two output voltages. First output was set to 100% rated voltage. The second output was set to the required the magnitude value. The disadvantages of this configuration are the generation of low frequency harmonics current component and higher losses when working in inductive region.

Bhavar *et al.*[16] presented Voltage Dips and Short Interruption Immunity Test Generator, to check the immunity of equipment against the voltage dips and short interruption, which occurs widely in low voltage mains and interface with electrical and electronics equipment connected to the mains. The output voltage waveforms of the immunity test generator are in full compliance with the standard IEC 61000 – 4 – 11. IEC 61000 – 4 – 11 is a common reference used to evaluate immunity of equipment while subjected to voltage dips or short interruptions. The 3 phase generator is designed for immunity testing of equipment operating at low voltage and using Motorized variac with Multi Tapping Transformer. The main disadvantage of this method is that the non-conducting pairs connected to the unselected taps dissipate power due to the taps. It has a complex structure and requires control of signal processors.

Rylander *et al.* [17] presented the voltage sag station is to test the transient response of loads due to voltage sags. With this station, one can determine accurate individual and composite load models which can enhance the results of transient stability studies. The voltage sag source is used a variable voltage transformer (VARIAC). This allows the

user to manually adjust the desired fault voltage. The main disadvantage of this method is that the non-conducting pairs connected to the unselected taps dissipate power due to the taps. It has a complex structure and requires control of signal processors.

Ma and Karady [18] presented a transformer-based voltage sag generator (VSG) suitable to evaluate the susceptibility of electrical equipment to voltage sag. The built VSG utilized one auto-transformer and two solid state relays (SSRs) to provide nominal voltage and sag voltage to the load. The switch statuses of two SSRs are controlled by nominal voltage and sag voltage duration signal produced by electronic circuits. But the system has limited performance due to the discontinuity in the voltage waveform. The approach has not been explored to sufficient depth either.

S. Osman and Ahmet M. Hava [19] presented a simple sag generator, its design is discussed, and its feasibility is demonstrated by experiments. The proposed solid-state relay and variable transformer (variac)-based sag generator is built for three-phase 10-kVA ratings, and balanced/imbalance voltage sags are demonstrated in the laboratory. The performance under resistive, inductive, and nonlinear loads is evaluated, and finally, the utilization of the sag generator in the test of a series active-filter-based power quality conditioner is demonstrated. In addition, advanced sag generation issues such as automating sag tests and adding sag phase-shift and point-of-initiation features to the sag generator have not been in this study.

Oranpiroj *et al.*[21] presented a 3-phase 4-wire voltage sag generator. Voltage sag generator is based on 3-phase 4-leg abc coordinate algorithm inverter, in order to handle the neutral current caused by the unbalance and non-linear load. The controller used for this voltage sag generator is a low-cost dsPIC microcontroller, fast response. The paper describes software SagWave to simulate and create controlled signal. Software allows the user to directly program the voltage sag waveform by selecting the sag magnitude, sag duration, phase shift and voltage sag type. By the way, inverter was presented cannot work individual, its work with SagWave software GUI generated data for microcontroller.

R. Zhang *et al.* [22] presented four-leg voltage-source converters can effectively provide the neutral connection in three-phase four-wire systems. They can be used in inverter, rectifier, and active filter applications to handle the neutral current caused by the unbalanced and/or nonlinear load or unbalanced source. And in research used three-dimensional (3-D) space vector modulation (SVM) schemes are proposed for controlling the four-leg voltage-source converters.

K. Zhou and D. Wang [23] presented the relationship between space-vector modulation and three-phase carrier-based pulse width modulation (PWM). The relationships involved, such as the relationship between modulation signals (including zero-sequence component and fundamental components) and space vectors, the relationship between the modulation signals and the space-vector sectors, the relationship between the switching pattern of space-vector modulation and the type of carrier, and the relationship between the distribution of zero vectors and different zero-sequence signal are systematically established.

J.H. Kim and S.K. Sul, [24] presented a voltage modulation method based on a triangular carrier wave for the three-phase four-leg voltage source converter. The four-leg converter can produce three output voltages independently with one additional leg. The proposed modulation method for the four-leg converter can be implemented with a single carrier by a simple but useful “offset voltage” concept. The method is equivalent to the so called three-dimensional space vector PWM method, but its implementation is much easier. The maximum magnitude of the balanced three-phase voltage and the maximum magnitude of zero sequence voltage, which can be synthesized simultaneously, are derived.

T. Glasberger *et al.* [25] presented an improved carrier-based PWM (CBPWM), which employs control of voltage offset via control of the fourth inverter leg. Further, control algorithms enabling operation of the supply unit under arbitrary load conditions (linear, non-linear, symmetrical, unsymmetrical etc.) in any case with sinusoidal voltages at the converter output are described. Behaviour of the designed control system with both 3D-

SVPWM and CBPWM strategies has been verified on a laboratory prototype of the power supply unit.

### **1.3 Purposes of the Study**

1.3.1 To design and prototype construction of 3-phase, 4-leg voltage sag generator prototype.

1.3.2 To develop a control sag signal algorithm for 3-phase, 4-leg generator based on a carrier-based three-dimensional space vector PWM technique (CBPWM).

1.3.3 To test overall system based on IEC 61000 and SEMI F47

### **1.4 Education/Application Advantages**

1.4.1 To obtain a voltage sag generator prototype for test the immunity of an electrical equipment based on IEC 61000 and SEMI F47.

1.4.2 To obtain an efficient and easy to change algorithm to control 3-phase, 4-wire, 4-leg voltage sag generator.

### **1.5. Research scope and methods**

#### **1.5.1 Research scope**

1.5.1.1 To design, construct and test 3-phase, 4-wire, 4-leg generator rated 3kVA. The system can supply voltage source to non-linear and/or unsymmetrical load.

1.5.1.2 To develop sag signal algorithm for voltage sag converter control 3-phase, 4-leg generator based on a carrier-based three-dimensional space vector PWM technique (CBPWM).

1.5.1.3 To test immunity of electrical device with IEC61000-4-11 and SEMI F47 standard.

#### **1.5.2 RESEARCH METHODS**

1.5.2.1 To study 3-phase, 4-leg voltage source converter topology.

1.5.2.2 To study, design, construct and test 3-phase, 4-wire, 4-leg inverter.

1.5.2.3 To develop sag signal algorithm for voltage sag 3-phase, 4-wire, 4-leg generator based on carrier-based three-dimensional space vector PWM technique (CBPWM).

1.5.2.4 To test overall system.

## **1.6 Research Contributions**

Department of Electrical Engineering, Faculty of Engineering, Chiang Mai University, Chiang Mai, Thailand.

## **1.7 Thesis Organization**

This thesis is organized in five (5) chapters and is structured in the following manner. Chapter 1 includes introduction of this thesis such as objective and scope of this project. Chapter 2 provides a brief review on power quality, voltage sag theory, the characteristics of voltage sag and voltage sag structures. In Chapter 3, the methodology of modelling of voltage sag generator as well as its simulation using PSIM, MATLAB-GUI and design of voltage sags generator with CBPWM technique and develop dsPIC microcontroller for drive IGBT gate use for 3 phase 4 wire voltage source inverter are presented. Chapter 4 presents the results of simulation and experiment of voltage sags generator with international standard test condition. The explanations and discussions on results obtained also be presented in this chapter. Chapter 5 concludes the work presented in this thesis. This chapter also briefs several suggestions for this project for future work and research.

Copyright © by Chiang Mai University  
All rights reserved